

Reasons To Buy Bobcat Exhaust Purifiers



Exhaust Purifiers

1 Cost Effective

The exhaust purifier replaces a section of the original exhaust system and requires no significant exhaust system modification. Direct-fit purifiers significantly reduce cost and installation time.

2 Clean Environment

When properly installed and maintained, equipment fitted with an exhaust purifier can significantly reduce certain emissions resulting in a cleaner and healthier work environment.

3 Quick Performance

The exhaust purifier offers excellent gas purification utilizing advanced catalyst technology.

4 High Durability

An internal brazed steel honeycomb along with a heavy duty external housing maintains a robust and durable exhaust system.

5 Product Availability

Over 80 different exhaust purifier designs are available through your Bobcat dealer.

6 Low Maintenance

Bobcat Exhaust Purifiers typically require very little maintenance. However, to ensure your purifier is performing effectively and efficiently, perform the recommended service as shown on the machine service schedule.



**Warning: All Exhaust Gases Can Kill.
Always Ventilate.**



Bobcat Company • 403 Airport Road • Bismarck, ND 58504

Increase profits while making
your Bobcat® equipment,
and workplace, environmentally friendly.

Increased Profits



An S150 Bobcat Skid Steer, equipped with an exhaust purifier, working in a paper recycling plant.

Bobcat® Exhaust Purifiers are designed to be installed on most Bobcat equipment models, reducing cost and installation time. A catalytic exhaust purifier is a device, which is integrated into a power unit's exhaust system to reduce certain components of exhaust gases. By installing an exhaust purifier on your Bobcat equipment, you may further your access to indoor and outdoor job sites that have emission regulations for carbon monoxide, hydrocarbons and particulate matter.

Increased Versatility & Safety

- Work conditions are improved by reduction of irritating exhaust odors
- Help achieve compliance for emissions regulations

Quick & Easy Installation

- No significant exhaust system modifications needed
- Reduces expensive installation time

Unmatched Durability

- Heavy-duty designs and superior workmanship
- Long life and durability provides greater long-term savings

Low Backpressure

- Minimal exhaust flow restrictions
- Virtually no power loss or fuel penalty

Low Maintenance

- Maintains workplace productivity
- Helps reduce costly equipment downtime

Reduced Emissions

Make your equipment and workplace environmentally friendly by using a Bobcat Exhaust Purifier. Exhaust purifiers help meet emission standards by dramatically reducing Particulate Matter (PM), popularly known as Diesel Soot, by up to 40%, Hydrocarbons (HC) by up to 80% and Carbon Monoxide (CO) by up to 90%.

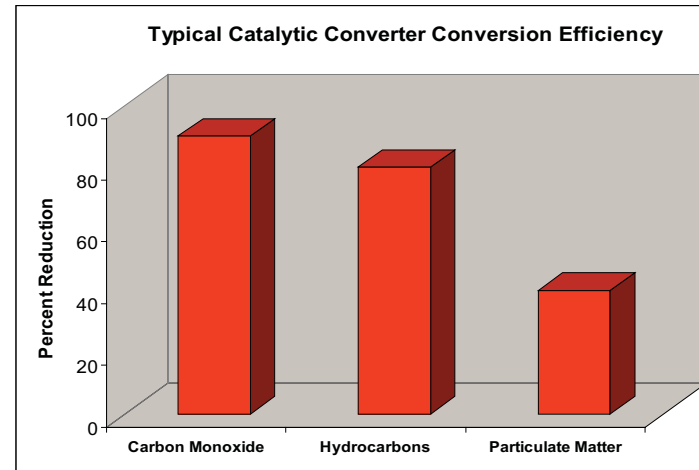

Bobcat Exhaust Purifiers represent the most advanced catalyst technology designed for high reductions of diesel soot, carbon monoxide and hydrocarbons. Each exhaust purifier contains a brazed steel catalyst honeycomb, the highest quality catalyst substrate in the industry.

A close-up view showing the brazed stainless steel honeycomb cells.

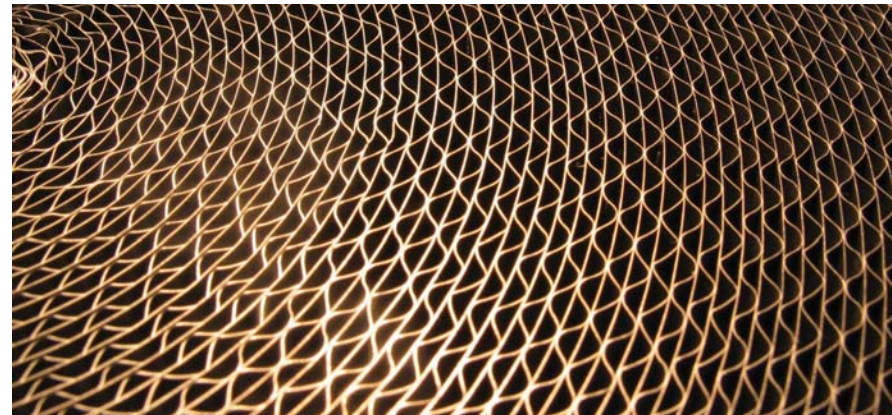

Wide Selection

There are over 80 exhaust purifier designs for nearly all Bobcat equipment models. Installing a Bobcat Exhaust Purifier is quick and easy since it is a replacement for the original exhaust component. For more information on exhaust purifier selection, please contact your local Bobcat dealer.

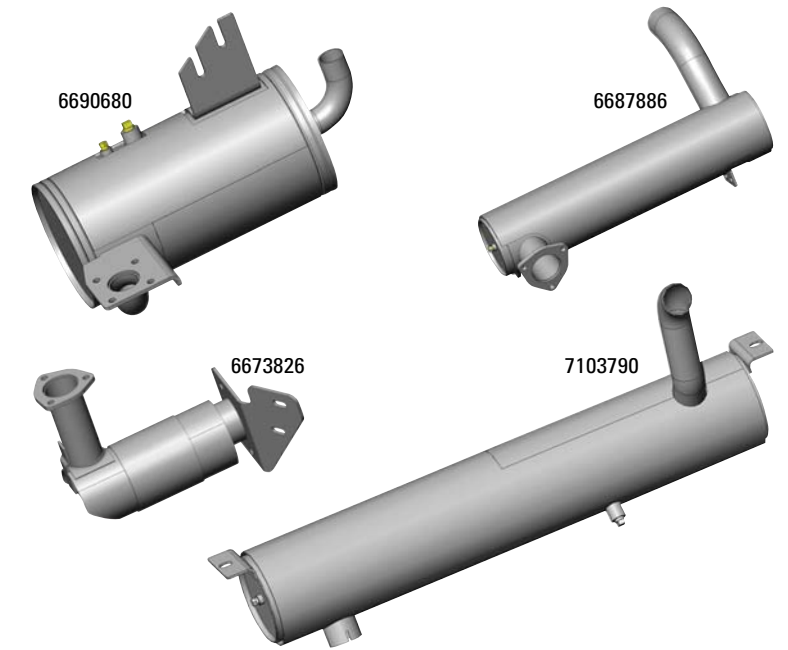

Bobcat exhaust purifiers are a direct-fit for many Bobcat machines like the S205.

